

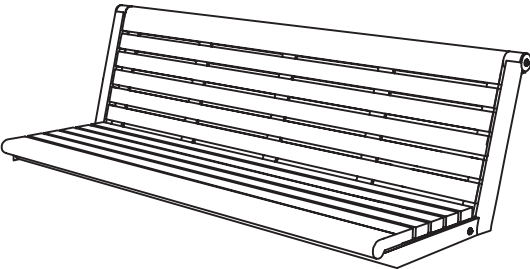

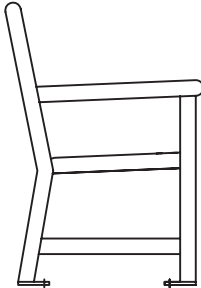

Compotents

| REF | Illustration | Description | QTY |
|-----|---|--------------------------------------|--------|
| A |  | Seat | 1 |
| B |  | Seat supports | 2 |
| C |  | 10-1.50mm x 75mm bolts washers | 6 6 |
| D |  | Wedge Anchors | 4 |



Tools Required

Long arm hex key, wrench, and linesman plier.

Recommendations

* To protect the powdercoating finish during assembly, please place unwrapped powdercoated parts on non-marring surface. Please do not place parts on cement or other hard surface. If damage on finish occurs, please use touch-up paint to avoid rust in future.

* Insert screws and install hex nuts with washers and tighten carefully to avoid damaging finish.

Assembly

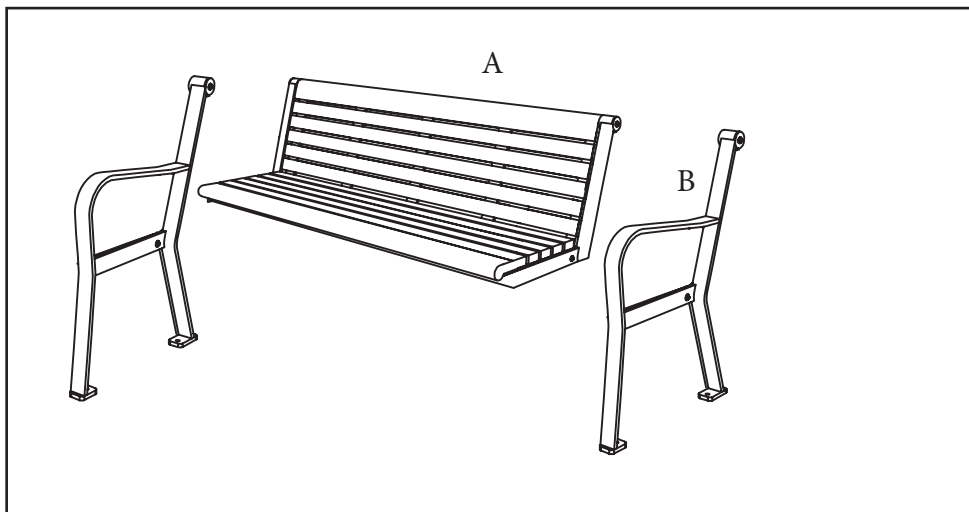

1. Assemble the seat supports(B) and the seat (A) with bolts and washers (C).
Insert bolts (C) loosely.

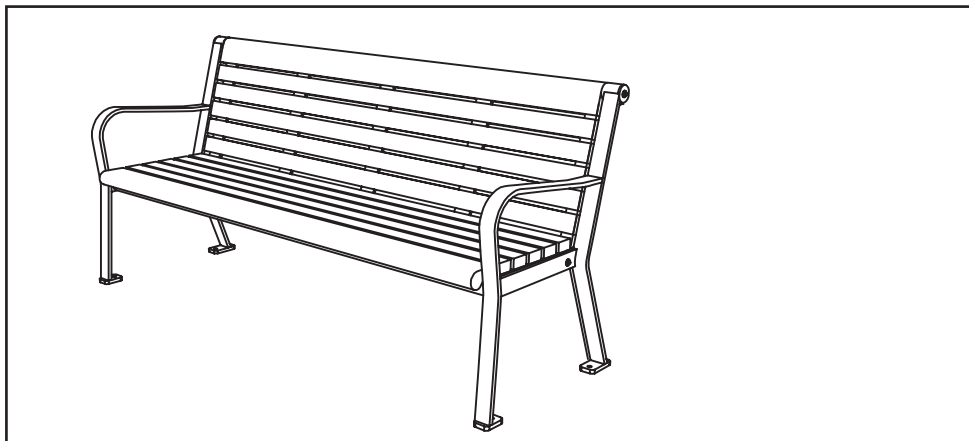

2. Fasten all the bolts.



Instruction for Surface Installation

1. Drill the proper size and depth hole.

That the holes are too large can usually be detected earliest when the wedge anchors moves forward by more than a fraction of an inch (1/4" max) during tightening.

2. Clean all the dust out of the hole with a blower or similar tool.

3. Hammer the expansion bolt into the hole.

Gently tap the wedge anchors until it is at the bottom of the drilled hole.

Two or three solid blows to compact the lead.

4. Tighten the nuts firmly.

Make sure the nut has not been over tightened; otherwise you can cause unnecessary stress on the wedge anchors and cause it to break.

