

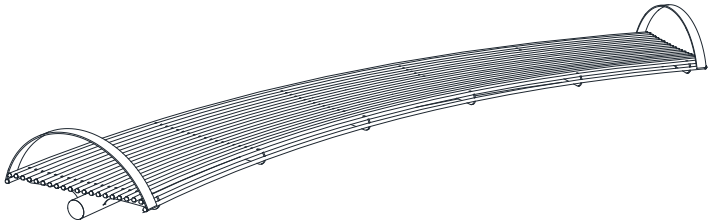

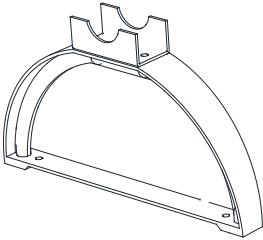

Components

REF	Illustration	Description	QTY
A		Seat	1
B		Seat supports	3
C		M10 Connecting Screws	6
D		Wedge Anchors	6



Tools Required

Long arm hex key, wrench, and linesman plier.

Recommendations

*In order to avoid damages to the powdercoat finish, please leave all unwrapped parts on a non-marring surface. Do not place unassembled parts on rough surfaces such as cement. Apply touch-up paint on damages or scratches immediately to prevent rust build-up.

* Install screws, bolts and hex nuts with washers. Tighten carefully to avoid damaging finish.

Assembly

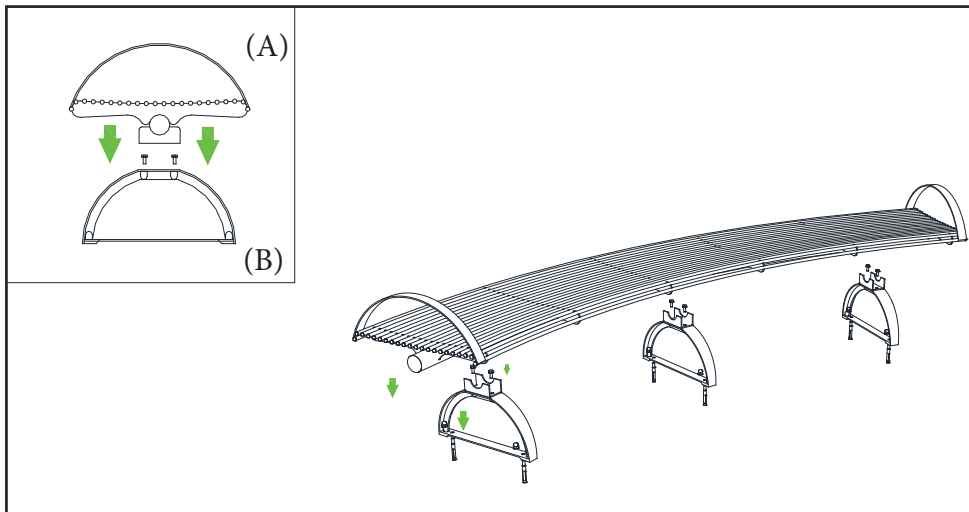

1. Assemble bench top (A) with bench support (B) using the bolts provided. Do not tighten the bolts until all pieces are correctly aligned.

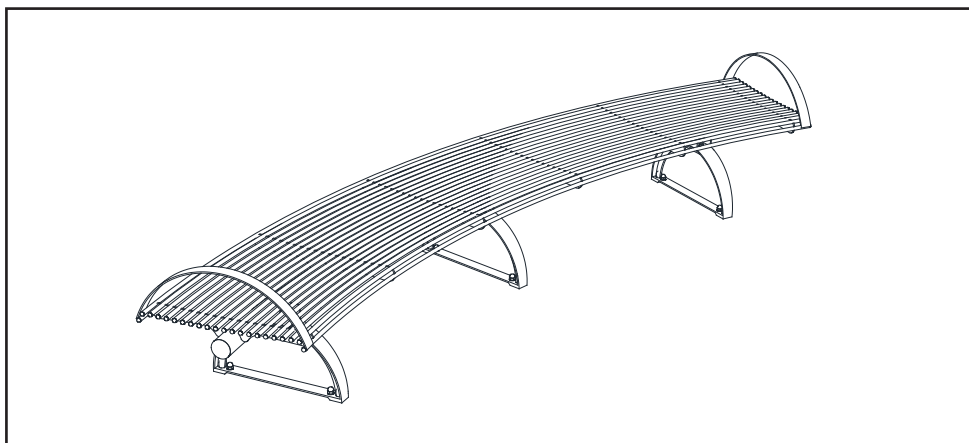

2. Fasten all bolts and finish.



Instruction for Surface Installation

1. Drill hole with proper size and depth.

Holes that are too large can usually be detected when the wedge anchors moves forward by more than a fraction of an inch (1/4" max) during tightening.

2. Remove any dust or residues from the hole with a blower or similar tool.

3. Hammer the expansion bolt into the hole.

Gently tap the wedge anchors until it is at the bottom of the drilled hole, followed by two or three solid blows to compact the lead.

4. Tighten the nuts firmly.

Make sure the nut has not been over tightened; unnecessary stress on the wedge anchors can cause it to break.

