

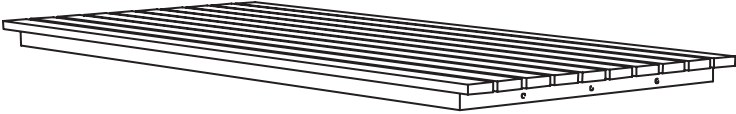

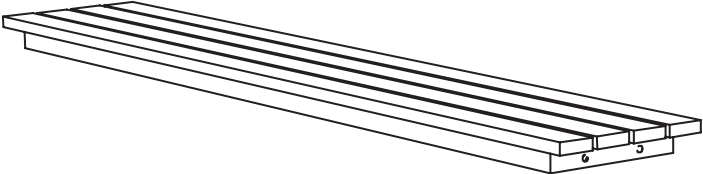

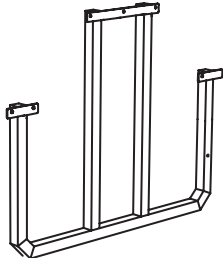

### Components

REF	Illustration	Description	QTY
A		Table top	1
B		Seats	2
C		Table supports	2
D		Support brace	2
E		10-1.50mm x 25mm bolts	12
		Hex nuts	12
		washers	24
F		10-1.50mm x 75mm bolts	4
		washers	4
F		Wedge Anchors	4



## Tools Required

---

Long arm hex key, wrench, and linesman plier.

## Recommendations

---

\* To protect the powdercoating finish during assembly, please place unwrapped powdercoated parts on non-marring surface. Please do not place parts on cement or other hard surface. If damage on finish occurs, please use touch-up paint to avoid rust in future.

\* Insert screws and install hex nuts with washers and tighten carefully to avoid damaging finish.

## Assembly

---

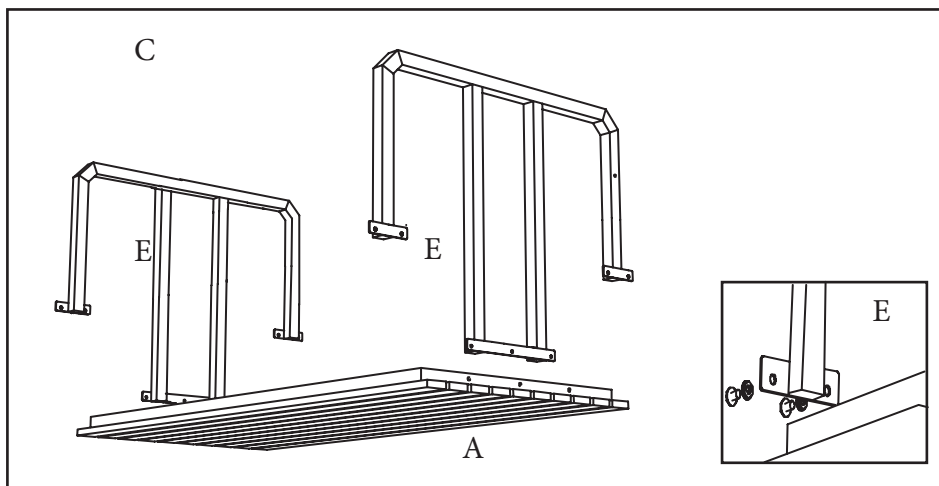

1. Turn table top upside down on a non-marring surface.

2. Place table support (C) upside down on table top (A). Insert bolts (E) loosely.



## Assembly

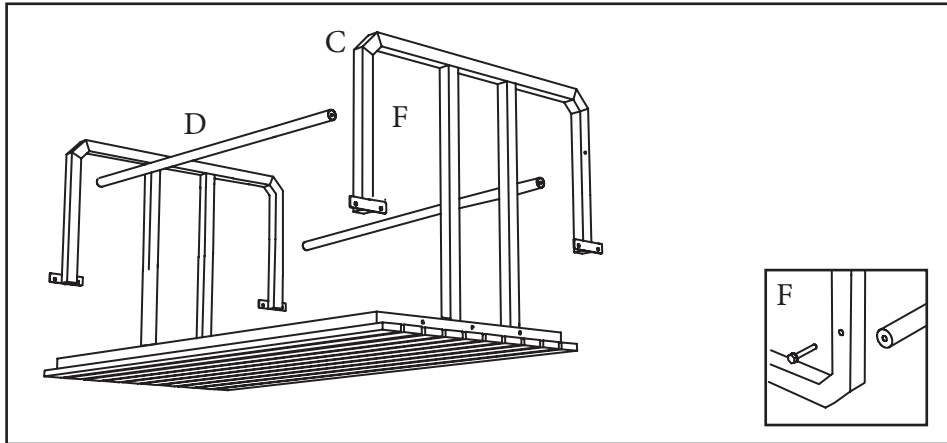

3. Connect table brace (D) to the middle of table support (C) with bolts (E) loosely.

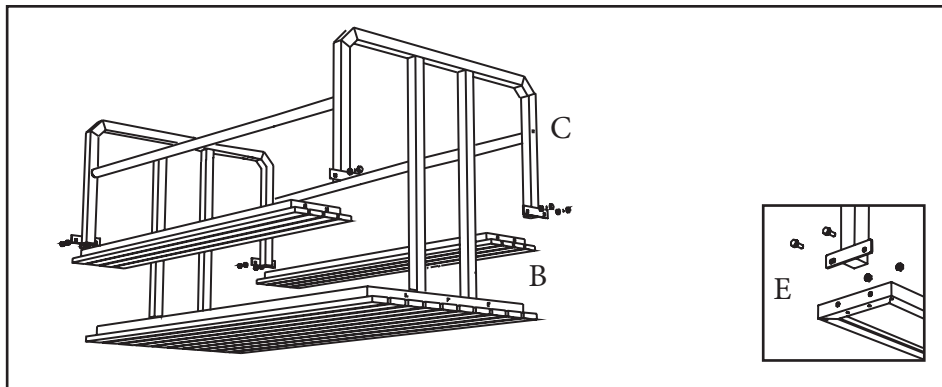

4. Connect seats with seat supports (C), and insert bolts (E) loosely.

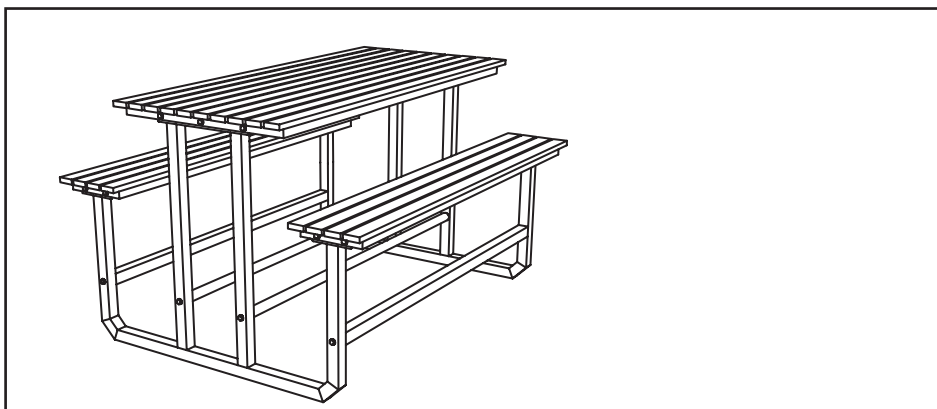

5. Fasten all bolts and nuts.

6. Turn picnic table upright with at least 2 people.



## Instruction for Surface Installation

---

1. Drill the proper size and depth hole.

That the holes are too large can usually be detected earliest when the wedge anchors moves forward by more than a fraction of an inch (1/4" max) during tightening.

2. Clean all the dust out of the hole with a blower or similar tool.

3. Hammer the expansion bolt into the hole.

Gently tap the wedge anchors until it is at the bottom of the drilled hole.

Two or three solid blows to compact the lead.

4. Tighten the nuts firmly.

Make sure the nut has not been over tightened; otherwise you can cause unnecessary stress on the wedge anchors and cause it to break.

