

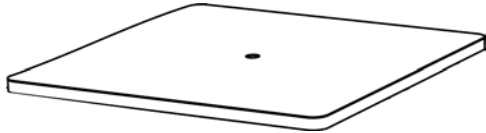





Components

REF	Illustration	Description	QTY
A		Table top	1
B		Seats	4
C		Table supports	4
D		Support brace	1
E		10-1.50mm x 25mm bolts Hex nuts Washers	
F		10-1.50mm x 75mm bolts Washers	
G		Wedge Anchors	

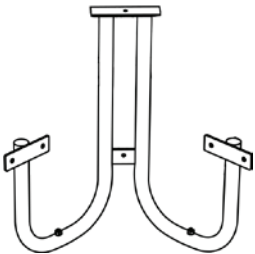
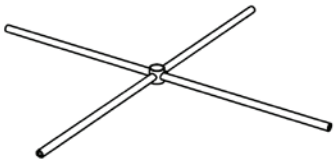

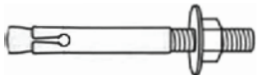
Tools Required

Long arm hex key, wrench, and linesman plier.

Recommendations

* To protect the powdercoating finish during assembly, please place unwrapped powdercoated parts on non-marring surface. Please do not place parts on cement or other hard surface. If damage on finish occurs, please use touch-up paint to avoid rust in future.

* Insert screws and install hex nuts with washers and tighten carefully to avoid damaging finish.

Assembly

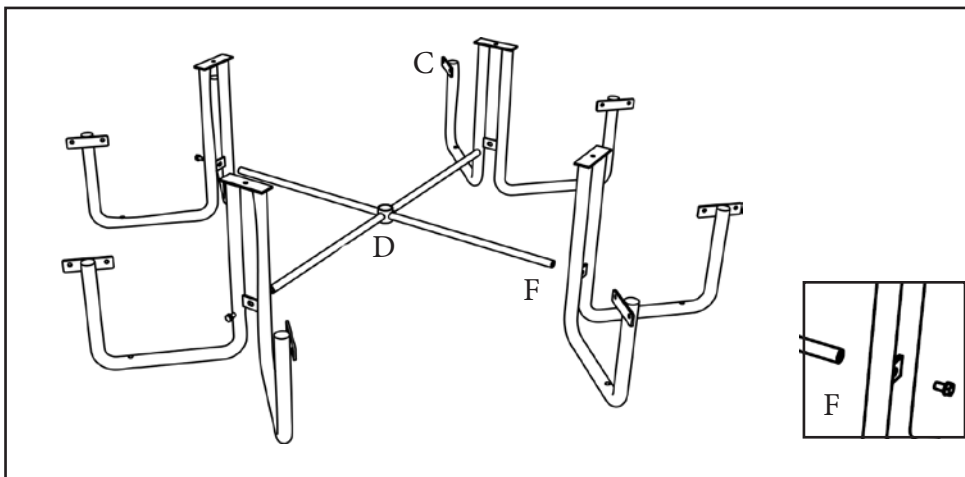

1. Connect support brace (D) to the middle of table support (C) with bolts (F) loosely.



Assembly

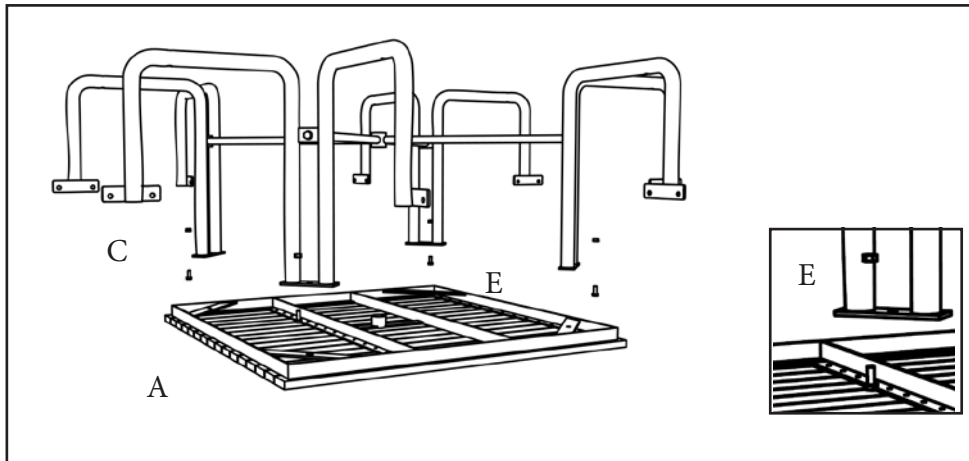

2. Turn table top upside down on a non-marring surface.

3. Place table support (C) upside down on table top. Insert bolts(E) loosely.

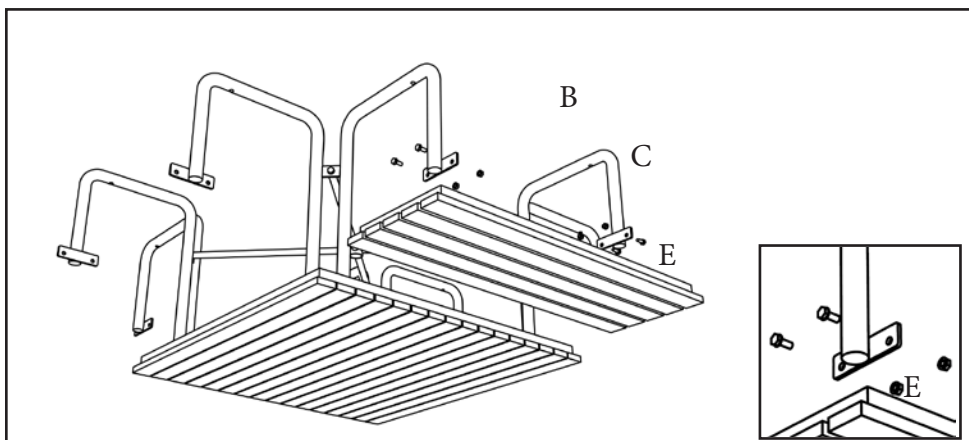

4. Connect seats (B) with table/seat supports(C), and insert bolts(E) loosely.

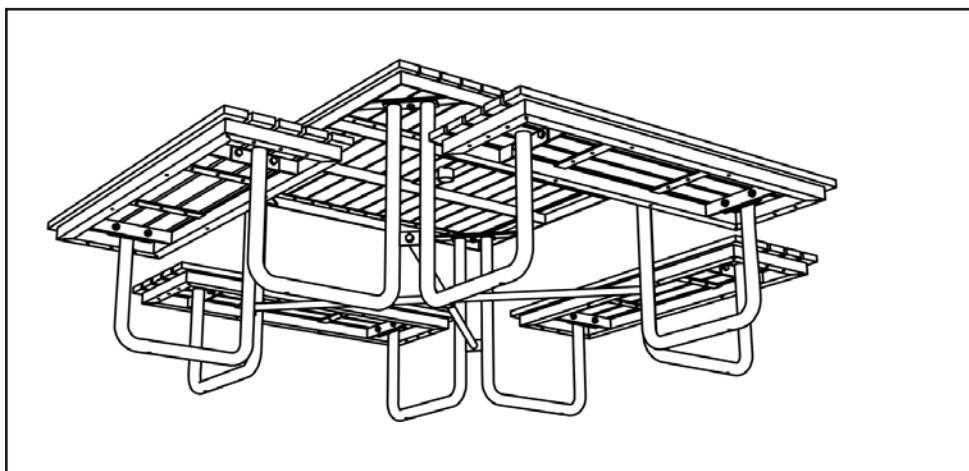

5. Fasten all bolts and nuts.

6. Turn picnic table upright with at least 2 people.



Instruction for Surface Installation

1. Drill hole with proper size and depth.
Holes that are too large can usually be detected when the wedge anchors moves forward by more than a fraction of an inch (1/4" max) during tightening.
2. Remove any dust or residues from the hole with a blower or similar tool.
3. Hammer the expansion bolt into the hole.
Gently tap the wedge anchors until it is at the bottom of the drilled hole, followed by two or three solid blows to compact the lead.
4. Tighten the nuts firmly.
Make sure the nut has not been over tightened; unnecessary stress on the wedge anchors can cause it to break.

