

Model no: CAT-031N

Material: Constructed with galvanized steel
Finish: Steel components are electrocoated with anti-corrosion treatment, and finished with UV resistant Canaan 5 Steps Powder Coating electrostatically
Installation: Surface mounted: holes are pre-drilled in each foot for securing to base
Specification: Choice of powdercoat color
Options: Umbrella mount available

Dimensions: Height: 29.5" / 750 mm
 Total Length: 74.8" / 1900 mm
 Table Top: 39.4" / 1000 mm Diameter
 Weight: 90 kg / 198.4 lbs

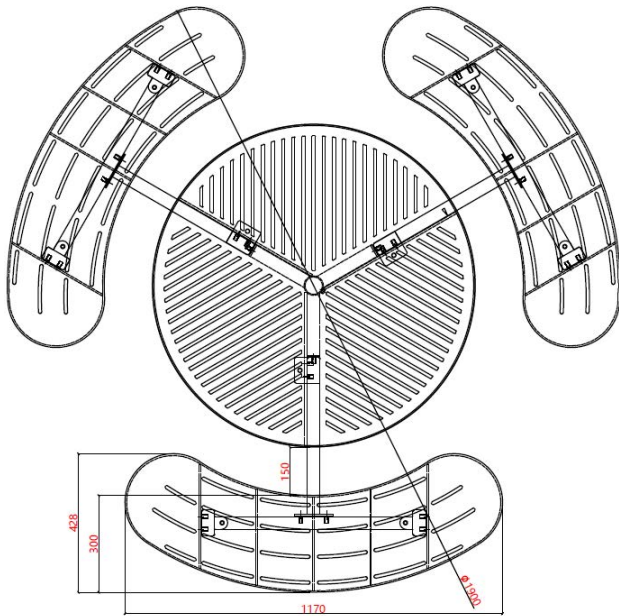

Top View

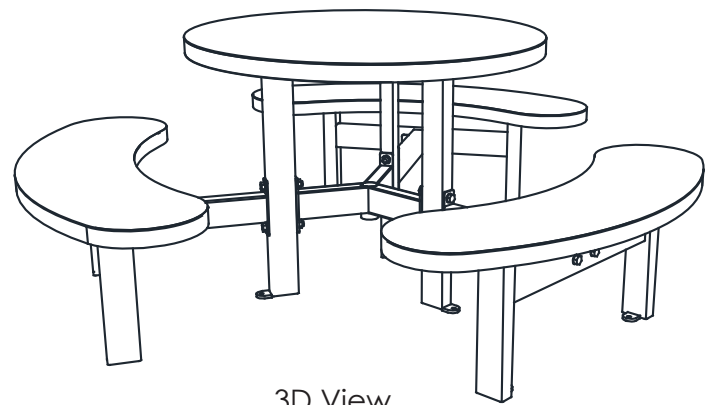

3D View

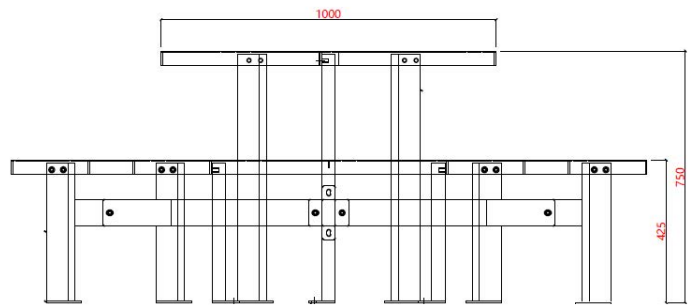

Front View

<p>Proprietary and confidential</p> <p>All the information contained in this drawing is the property of Canaan Inc. Reproduction of the drawing in whole or in part is prohibited without the written consent of Canaan Inc. Copyright © 2017 Canaan Inc. All rights reserved.</p>	<p>Unless otherwise specified</p> <p>All measurements are in mm; all measurements are also preliminary and may vary from final plans. We reserve the right to improve, alter or discontinue specifications without notice.</p>	
---	---	---

Accessibility (ADA) Configuration

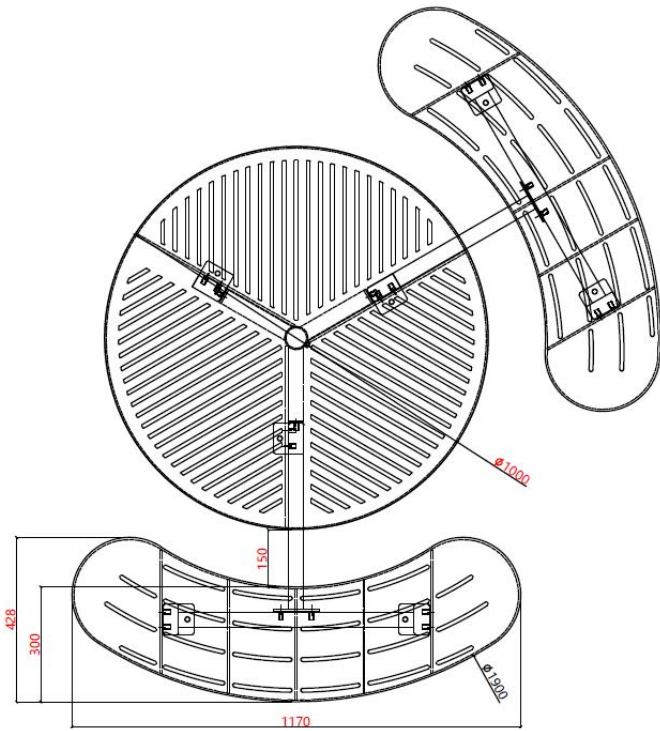

Top View

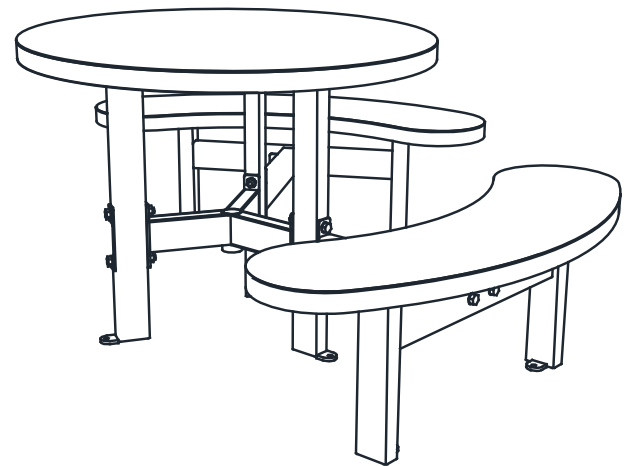

3D View

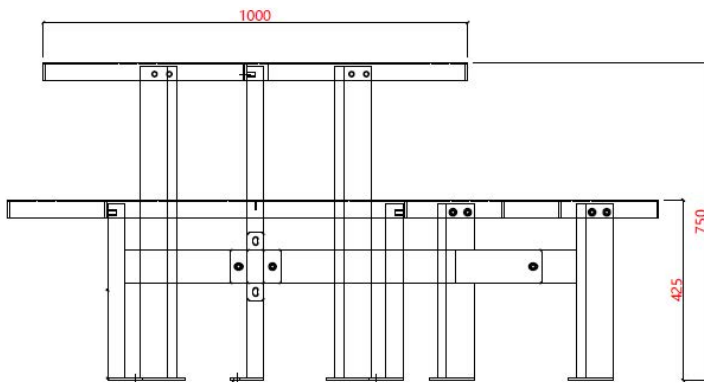

Front View

Proprietary and confidential	Unless otherwise specified	
<p>All the information contained in this drawing is the property of Canaan Inc. Reproduction of the drawing in whole or in part is prohibited without the written consent of Canaan Inc. Copyright © 2017 Canaan Inc. All rights reserved.</p>	<p>All measurements are in mm; all measurements are also preliminary and may vary from final plans. We reserve the right to improve, alter or discontinue specifications without notice.</p>	