

Model no: CAT-201HDPE

- Material:** Constructed with recycled plastic and framed with galvanized steel
- Finish:** Steel components are electro-coated with anti-corrosion treatment, and finished with UV resistant Canaan 5 Steps Powder Coating electro-statically
- Installation Specification:** Surface mounted: holes are pre-drilled in each foot for securing to base
- Options:** Choice of powder coated color
- Options:** Wheelchair accessibility and umbrella mount available
- Dimensions:**
 - Height: 29.5" / 750 mm
 - Width: 85.1" / 2162 mm
 - Length: 85.1" / 2162 mm
 - Umbrella Hole: $\phi 41$

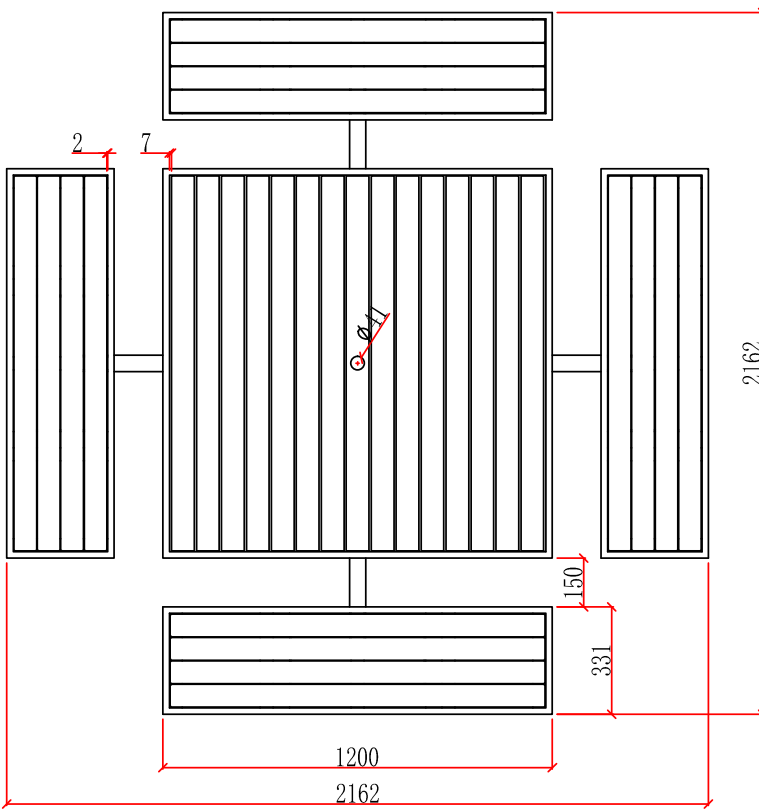

Top View

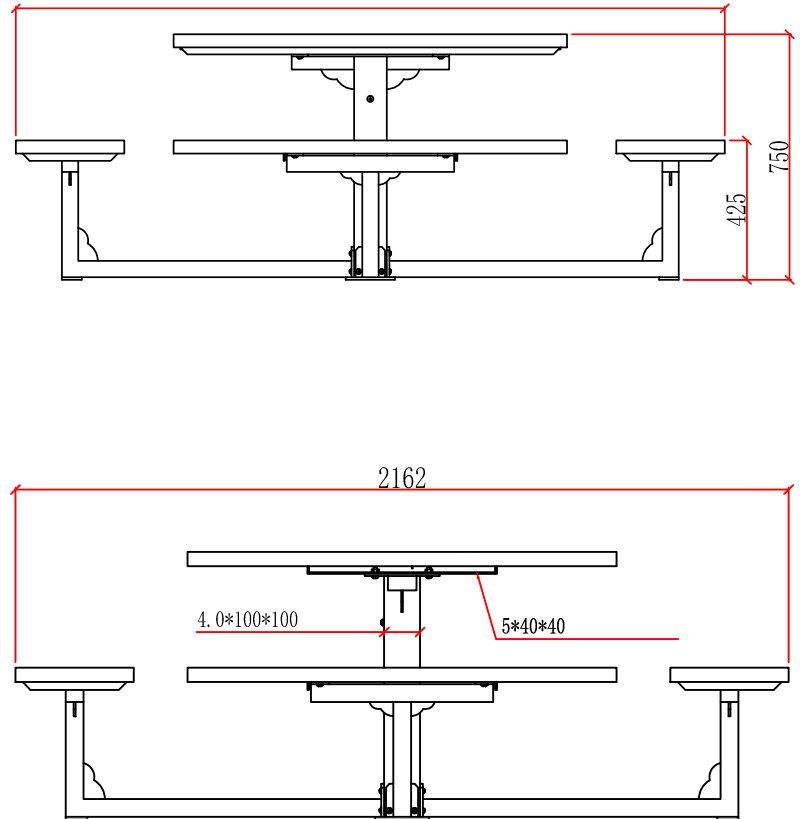

Side View

Proprietary and confidential	Unless otherwise specified	
<p>All the information contained in this drawing is the property of Canaan Inc. Reproduction of the drawing in whole or in part is prohibited without the written consent of Canaan Inc. Copyright © 2017 Canaan Inc. All rights reserved.</p>	<p>All measurements are in mm; all measurements are also preliminary and may vary from final plans. We reserve the right to improve, alter or discontinue specifications without notice.</p>	