

Front View

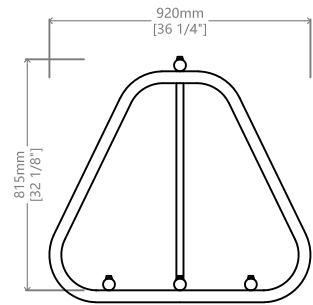

Side View

Length: 116 1/2" / 2960 mm Width: 36 1/4" / 920 mm Height: 34 1/8" / 866 mm Weight: 94.8 lbs. / 43 kg

Materials:

Constructed with H.S. Galvanized Steel Tube.

Finish:

Steel components are electrocoated with anti-corrosion treatment and finished with UV resistant Canaan 5 Steps Powder Coating electrostatically.

Installation:

Free standing or surface mount: holes are pre-drilled in each foot for securing to base.

Options:

- Perforation patterns Powdercoat color
- Custom Size



Proprietary and confidential

All the information contained in this drawing is the property of Canaan Inc. Reproduction of the drawing in whole or in part is prohibited without the written consent of Canaan Inc. Copyright © 2016 Canaan Inc. All rights reserved.

Unless otherwise specified

All measurements are in mm; all measurements are also preliminary and may vary from final plans. We reserve the right to improve, alter or discontinue specifications without notice.

TF: 1-877-305-6638
Fax: 1-866-806-2355
Email: info@canaansf.com
www.canaansitefurnishings.com