

Front View

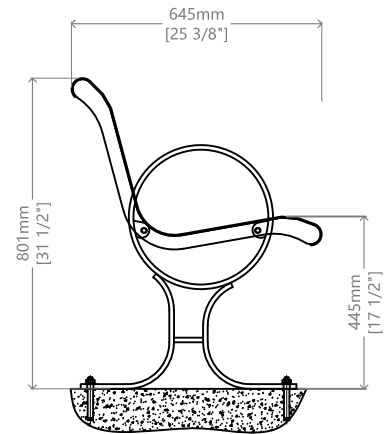

Side View

Length: 76 3/8" / 1940 mm    Width: 25 3/8" / 645 mm    Height: 31 1/2" / 801 mm    Weight: 183 lbs. / 83 kg

**Materials:**

Constructed with galvanized steel flat bar and H.S. steel tubing

**Finish:**

Steel components are electrocoated with anti-corrosion treatment and finished with UV resistant Canaan 5 Steps Powder Coating electrostatically.

**Installation:**

Surface mounted: holes are pre-drilled on each foot for securing to base.

**Options:**

- Perforation patterns
- Backless
- Additional armrests
- Memorial plaque
- Powdercoat color



**Proprietary and confidential**

All the information contained in this drawing is the property of Canaan Inc. Reproduction of the drawing in whole or in part is prohibited without the written consent of Canaan Inc. Copyright © 2016 Canaan Inc. All rights reserved.

**Unless otherwise specified**

All measurements are in mm; all measurements are also preliminary and may vary from final plans. We reserve the right to improve, alter or discontinue specifications without notice.

TF: 1-877-305-6638  
Fax: 1-866-806-2355  
Email: info@canaansf.com  
www.canaansitefurnishings.com