

Front View

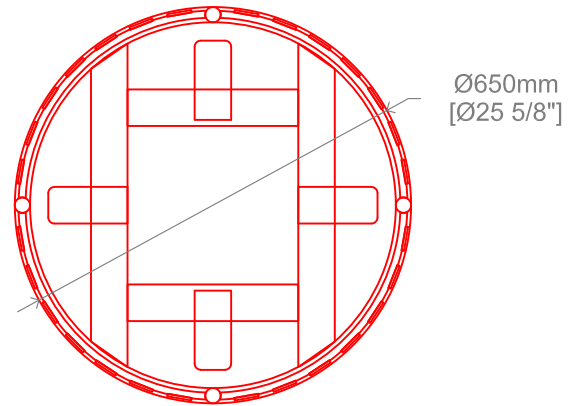

Top View

Diameter: 25 5/8" / 650 mm Height: 27" / 686 mm Weight: 158.7 lbs. / 72 kg

**Materials:**

The frame of the planter is constructed with heavy duty galvanized steel flat bar.

**Finish:**

Steel components are electrocoated with anti-corrosion treatment and finished with UV resistant Canaan 5 Steps Powder Coating electrostatically.

**Installation:**

Free standing or surface mount: holes are pre-drilled in each foot for securing to base.

**Options:**

- Perforation patterns
- Powdercoat color
- Custom Size



**Proprietary and confidential**

All the information contained in this drawing is the property of Canaan Inc. Reproduction of the drawing in whole or in part is prohibited without the written consent of Canaan Inc. Copyright © 2016 Canaan Inc. All rights reserved.

**Unless otherwise specified**

All measurements are in mm; all measurements are also preliminary and may vary from final plans. We reserve the right to improve, alter or discontinue specifications without notice.

TF: 1-877-305-6638  
Fax: 1-866-806-2355  
Email: info@canaansf.com  
www.canaansitefurnishings.com