

Top View

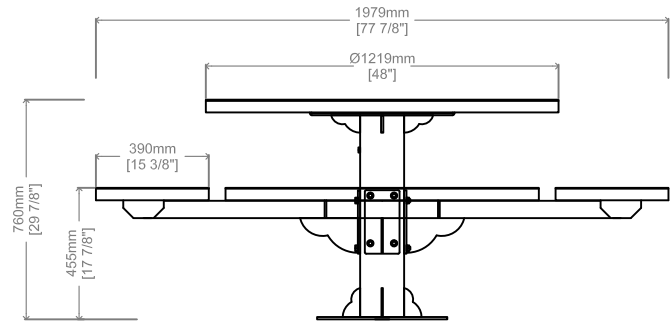

Side View

Total Length: 77 7/8" / 1979 mm Weight: 343.2 lbs. / 156 kg

Table Diameter: 48" / 1219 mm Table Height: 29 7/8" / 760 mm

Seat Length: 42 5/8" / 1083 mm Seat Width: 15 3/8" / 390 mm Seat Height: 17 7/8" / 455 mm

Materials:

Constructed with galvanized steel.

Finish:

Steel components are electrocoated with anti-corrosion treatment and finished with UV resistant Canaan 5 Steps Powder Coating electrostatically.

Installation:

Surface mounted: holes are pre-drilled on each foot for securing to base.

Options:

- Perforation patterns
- Backrest
- Powdercoat color
- Umbrella
- Wheelchair accessibility



Proprietary and confidential

All the information contained in this drawing is the property of Canaan Inc. Reproduction of the drawing in whole or in part is prohibited without the written consent of Canaan Inc. Copyright © 2016 Canaan Inc. All rights reserved.

Unless otherwise specified

All measurements are in mm; all measurements are also preliminary and may vary from final plans. We reserve the right to improve, alter or discontinue specifications without notice.

TF: 1-877-305-6638
Fax: 1-866-806-2355
Email: info@canaansf.com
www.canaansitefurnishings.com