

Side View

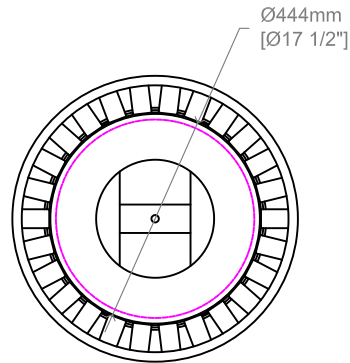

Top View

Capacity: D420 x H615 = 23 Gal Weight: 93 lbs. / 42 kg  
 Diameter: 23 7/8" / 605 mm Height: 35" / 890 mm

### Materials:

Constructed with Stainless Steel

### Finish:

Steel components are electrocoated with anti-corrosion treatment and finished with UV resistant Canaan 5 Steps Powder Coating electrostatically.

### Installation:

Free standing or surface mount: holes are pre-drilled in each foot for securing to base.

### Options:

- Push flap
- Custom label
- Custom liner
- Custom openings
- Perforation patterns
- Powdercoat color



#### Proprietary and confidential

All the information contained in this drawing is the property of Canaan Inc. Reproduction of the drawing in whole or in part is prohibited without the written consent of Canaan Inc. Copyright © 2016 Canaan Inc. All rights reserved.

#### Unless otherwise specified

All measurements are in mm; all measurements are also preliminary and may vary from final plans. We reserve the right to improve, alter or discontinue specifications without notice.

TF: 1-877-305-6638  
 Fax: 1-866-806-2355  
 Email: info@canaansf.com  
 www.canaansitefurnishings.com