

Front View

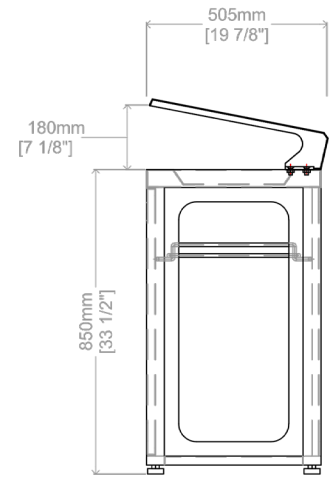

Side View

Length: 96" / 2440 mm Width: 19 7/8" / 505 mm Height: 41 3/8" / 1050 mm Weight: 335 lbs. / 152 kg

Materials:

Constructed with Galvanized Steel with transparent acrylic panels and vinyl decal.

Finish:

Steel(metal with powder coated finish is also available), Weather resistant, fire resistant, and resist fading by UV over time.

Installation:

Free standing or surface mount: holes are pre-drilled in each foot for securing to base.

Options:

- Push flap
- Custom label
- Custom liner
- Custom openings
- Additional bin
- Powdercoat color



Proprietary and confidential

All the information contained in this drawing is the property of Canaan Inc. Reproduction of the drawing in whole or in part is prohibited without the written consent of Canaan Inc. Copyright © 2016 Canaan Inc. All rights reserved.

Unless otherwise specified

All measurements are in mm; all measurements are also preliminary and may vary from final plans. We reserve the right to improve, alter or discontinue specifications without notice.

TF: 1-877-305-6638
 Fax: 1-866-806-2355
 Email: info@canaansf.com
 www.canaansitefurnishings.com