

Front View

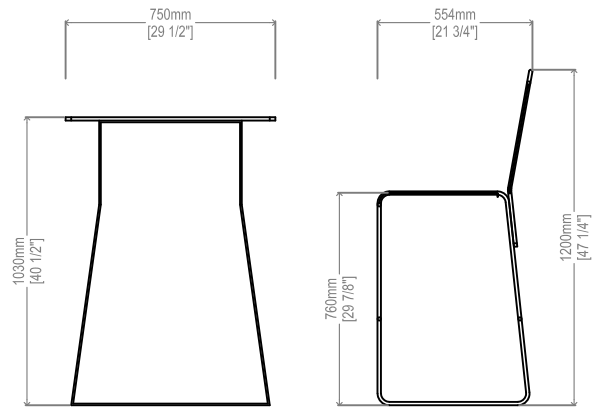

Side View

Table Length: 78 3/4" / 2000 mm Table Width: 29 1/2" / 750 mm Table Height: 40 1/2" / 1030 mm

Seat Length: 19 5/8" / 500 mm Seat Width: 21 3/4" / 554 mm Seat Height (with Backrest): 47 1/4" / 1200 mm

### Materials:

Constructed with galvanized steel.

### Finish:

Steel components are electrocoated with anti-corrosion treatment and finished with UV resistant Canaan 5 Steps Powder Coating electrostatically.

### Installation:

Surface mounted: holes are pre-drilled on each foot for securing to base.

### Options:

- Perforation patterns
- Powdercoat color
- Wheelchair accessibility
- Umbrella
- Backless



#### Proprietary and confidential

All the information contained in this drawing is the property of Canaan Inc. Reproduction of the drawing in whole or in part is prohibited without the written consent of Canaan Inc. Copyright © 2016 Canaan Inc. All rights reserved.

#### Unless otherwise specified

All measurements are in mm; all measurements are also preliminary and may vary from final plans. We reserve the right to improve, alter or discontinue specifications without notice.

TF: 1-877-305-6638  
 Fax: 1-866-806-2355  
 Email: info@canaansf.com  
 www.canaansitefurnishings.com

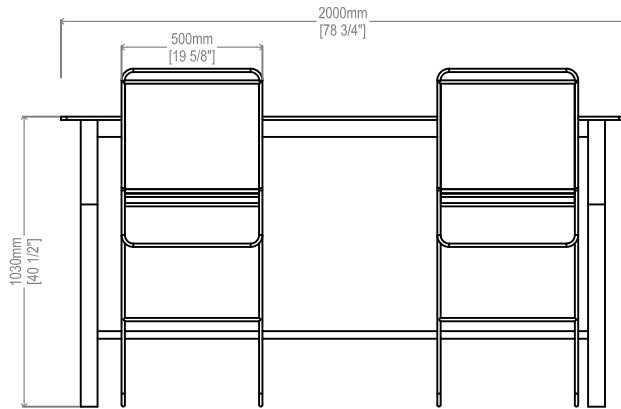

Front View

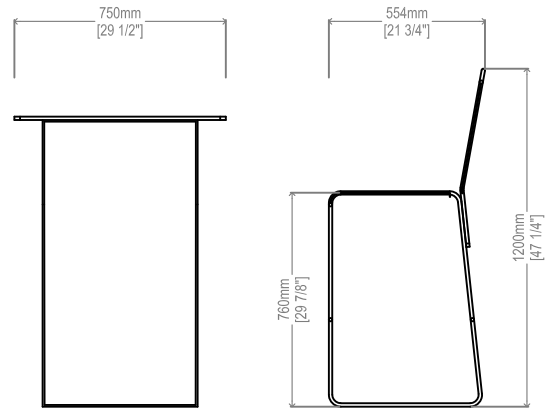

Side View

Table Length: 78 3/4" / 2000 mm Table Width: 29 1/2" / 750 mm Table Height: 40 1/2" / 1030 mm

Seat Length: 19 5/8" / 500 mm Seat Width: 21 3/4" / 554 mm Seat Height (with Backrest): 47 1/4" / 1200 mm

### Materials:

Constructed with galvanized steel.

### Finish:

Steel components are electrocoated with anti-corrosion treatment and finished with UV resistant Canaan 5 Steps Powder Coating electrostatically.

### Installation:

Surface mounted: holes are pre-drilled on each foot for securing to base.

### Options:

- Perforation patterns
- Powdercoat color
- Wheelchair accessibility
- Umbrella
- Backless



#### Proprietary and confidential

All the information contained in this drawing is the property of Canaan Inc. Reproduction of the drawing in whole or in part is prohibited without the written consent of Canaan Inc. Copyright © 2016 Canaan Inc. All rights reserved.

#### Unless otherwise specified

All measurements are in mm; all measurements are also preliminary and may vary from final plans. We reserve the right to improve, alter or discontinue specifications without notice.

TF: 1-877-305-6638  
 Fax: 1-866-806-2355  
 Email: info@canaansf.com  
 www.canaansitefurnishings.com